

RAILWAY MAGAZINE

International solutions for the railway industry

4 Efficient development
Time is short, requirements high: How the development engineers of Laspar Angst+Pfister turn this around.

20 Aging-resistant hoses
Leading train manufacturers have discovered the usefulness of this hose made entirely of metal, but nonetheless light and flexible.

26 Minimal elastic mounting
It weighs little, needs little space and will eventually travel along the Gotthard base tunnel.

Editorial



Dear Readers and Valued Customers,

What was it like in the past? What did we used to do? When I was a child, the chassis of a new car often began to rust after only one year. Today, this is no longer an issue. Even mechanically, everything is more sophisticated; the intervals between services are getting longer and longer. And now cars can drive themselves. Rail vehicle design has evolved just as rapidly – bringing even higher speeds and greater travelling comfort.

Technical advances always fascinate us – but then are very quickly taken for granted. At Angst + Pfister, we are lucky enough to have that fascination every day. Our engineering work is driving innovation and shaping the future. We can show our customers how to achieve weight reductions in their rail vehicle manufacturing so that the subsequent owners can reduce their operating costs. We feel privileged to be working on the technology of tomorrow.

And there is further reason for our passion: We like to find solutions together. Instead of commending ourselves to our customers, we would much rather listen to them: How do you go about developing new products? What hurdles do you have to overcome? How do you organize your production and logistics processes? In conversation, it usually emerges fairly quickly how and where we can help, and how their development times can be reduced. And we also think beyond the engineering of an item and integrate more functionality in a product, so that the customer can reduce the number of components and save on production and storage costs.

We get down to the nuts and bolts in this magazine: Read about how we go about developing a new vibration isolation for mounting power converters and how we managed to reduce the dimensions of the components to a minimum on pages 26/27. You might also be interested in how we deal with the new European standards for fire safety in rail vehicles. See how on pages 30/31.

Innovation cannot be forced. At Angst + Pfister, we have the right environment for innovation: We have 140 engineers and technicians working for Group Engineering in Zurich or as application engineers in various countries, for the CAD team in China or for the Research and Development Centre at the plant in Turkey. That's how competence and experience come together, and we believe in letting expertise and knowledge flow. We foster discussion, because we know that only in a team can a good solution become an even better one. Antivibration experts exchange ideas with colleagues who specialise in fluid technology, seals, plastics, or drive systems to discuss ideas. We constantly challenge ourselves and push boundaries – so without it being an exaggeration, we can say that we support our customers both technologically and economically and that they benefit from our innovations.

A handwritten signature in black ink that reads "E. Schmid". The signature is fluid and cursive.

Erich Schmid
Chief Technology Officer

Content



4



10



18



20



26



28



Solutions for the railway industry

Efficient development
Numerical simulation shortens the time-to-market and reduces the total cost of ownership **4**

Integrated fire safety
This new rubber compound is inherently compliant with the fire safety requirements of EN 45 545. Coating is superfluous **10**

So tracks last longer
 sleeper pads relieve stress on the tracks. The ECOVIB® USP are tested on the basis of the new standard **18**

Aging-resistant hoses
Elastomer hoses become porous, fixed metal pipes are inflexible. ASSIWELL® is the name of the solution **20**

Minimal elastic mounting
The power converter of the EC250, which will travel through the Gotthard, is mounted in a new and unusual way **26**

Residential construction on top of the tunnel
Easy-to-install insulation mats protect the building from vibration and noise **28**

CoverPhoto: ©iStock, Nikada

©Copyright by Angst+ Pfister 2016

Subject to alteration.

All technical specifications for information only. APSOvib®, APSOfuid®, APSOseal® and APSOdrive® are registered trademarks. The acronym APSO stands for Angst+ Pfister Solutions.

**Do you have any further questions
Won one of the topics in the magazine?**
Please send an e-mail to engineering@angst-pfister.com or call +41 44 306 62 57. We will contact you immediately.

Developments that bring technical and economic advantages

The development times are ambitiously short, the results are often even better than expected. This is what innovative companies want. And this is how it works for the Research & Development Centre of Laspar Angst+Pfister in Bursa, Turkey. The engineers develop solutions for antivibration and sealing technology that optimise the Total cost of ownership as well as the technology.



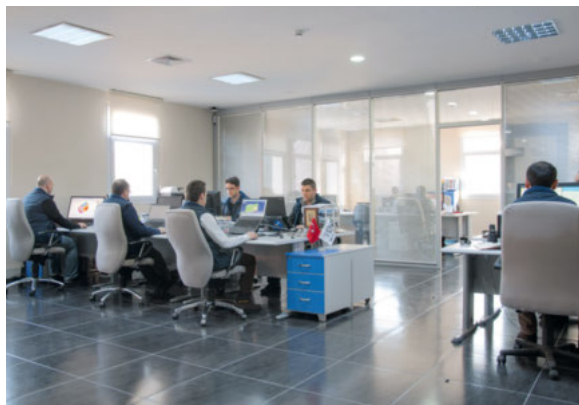

Around 40 professionals work at the development centre at Bursa.

Numerical simulation significantly reduces development time: Laspar specialists are applying their expertise daily in achieving this goal for Angst+Pfister.

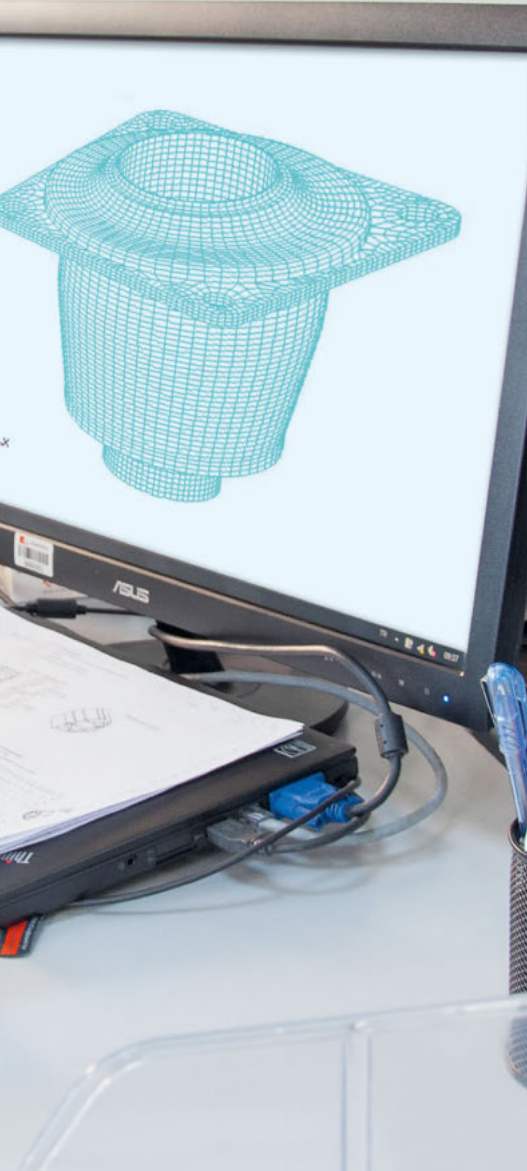

There is no question about it: All modern trains have floating floors to isolate vibration and absorb sound. The only imponderables for the train manufacturers are which materials and technologies to use. The development engineers from Laspar Angst+Pfister in collaboration with engineers from Stadler Bussnang AG have recently designed a new floor mount for the high-speed multiple unit train EC250, which Stadler Rail AG of Switzerland is constructing for the Swiss Federal Railways. It not only meets the latest requirements of the fire protection standard DIN EN 45 545, which defines the requirements of materials and components for rail vehicles, but also in cross-comparison the new floor bearing from Laspar Angst+Pfister is more efficient and more cost-effective.*

Short development phases

“After the co-design phase, our colleagues in Turkey usually need just six to nine weeks to produce prototypes,” said Erich Schmid, Chief Technology Officer for Angst+Pfister at the head office in Zurich. “We subject these to thorough tests and sometimes the customer also conducts

“Following the co-design phase, our colleagues in Turkey usually need no more than six to nine weeks to build the prototypes.”

Erich Schmid,
Chief Technology Officer,
Angst+Pfister, Zurich

tests at the same time,” added Eray Ulugül, the CEO of Laspar Angst+Pfister in Bursa. “Over another ten to thirteen weeks, we then use the serial production tool to produce the first samples.”

Practical and theoretical know-how

The reasons for the relatively short development times are as follows: The engineers in Bursa know precisely what the customers require. The 40-strong, highly qualified development team works closely worldwide with Angst+Pfister’s 100 application engineers, senior engineers and CAD engineers.

Time-saving numerical simulation

A further strength of the development team for Laspar Angst+Pfister is numerical simulation: “Using the finite element method, we have been able to significantly shorten the development process,” said Eray Ulugül. The specialists from Laspar Angst+Pfister are also experienced and suitably practiced in the calculation of loads to which a component is subjected throughout its lifetime.

Production under the same roof

One of the great advantages is the close proximity of the development team to production: Laspar was founded as a production company in 1982 and since then it has continued to develop further and expand. As part of the Angst+Pfister Group since 2013, Laspar Angst+Pfister now produces around 100 million antivibration and sealing components each year. The customers are

leading suppliers from the automotive sector, rail sector and ship construction. Laspar Angst+Pfister is also consulted for building construction and civil engineering and, specifically, bridge construction, and also for the production of agricultural machines and the manufacture and development of electronic and household appliances.

* Read more about floating floors and their vibration-isolating bearing on page 13. More about the high-speed multiple unit train EC250 on page 26 and the Fire Safety Standard DIN EN 45 545 on page 30.



Lean operations: Development, prototyping, testing, compounding and production are located under one roof at Laspar Angst+Pfister.

Test stations right next door

Laspar Angst+Pfister has the development expertise for customised solutions and the know-how for prototyping, initial samples and series production under one roof. “This really does allow us to keep the individual development loops and development times short in total,” said Erich Schmid. The test stations for testing are also within walking distance of the offices of the development engineers who can thus accelerate their virtual engineering. “We unite all our skills on site, this provides our customers time and cost savings,” commented Eray Ulugül. The development time is reduced and products come to market quicker.

Multiple certifications

Since January 2016, the Research & Development Centre for Laspar Angst+Pfister in Bursa has been recognized by the Turkish Ministry for Science, Industry and Technology. In addition, Laspar Angst+Pfister is certified along the entire value creation chain from development to production and delivery in accordance with ISO 9001, ISO TS 16949 and ISO 14001: All processes are based on a comprehensive quality management system and the company also meets the highest standards with regard to health, safety and the environment.

Integrating functionality

The development engineers from Laspar Angst+Pfister know how to include other aspects in addition to technology in their work: For example, if an anti-vibration or sealing component is able to unify additional functionalities within itself, the customers can reduce their storage and assembly costs: Instead of two or more parts, only one is needed. This reduces the total cost of ownership, which is reduced even further due to the generally long service life of the components.

This integrated way of looking at things becomes apparent in all areas of Angst+Pfister: The customer benefits from distinct development competences and also from higher purchasing and production efficiency and the thoughtful logistics that offer Just-in-Time, Kanban and Supply Chain Management solutions around the world. This is the integrated, and, from a cost perspective, interesting efficiency that the market needs.

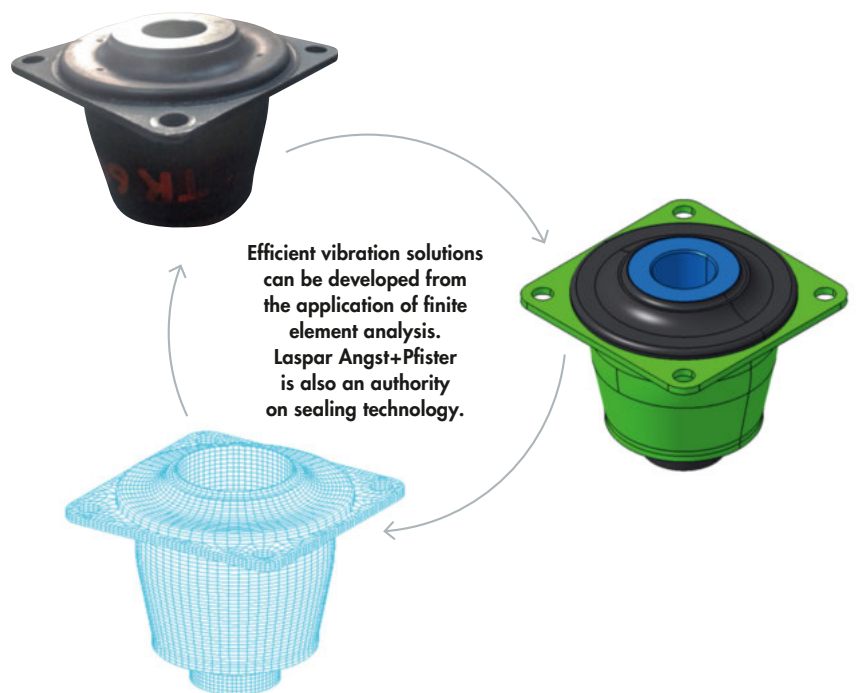

Eray Ulugül
CEO
Laspar Angst + Pfister
+90 224 280 69 00
Eray.Ulugul@lp-ap.com



The fire safety standard DIN EN 45 545 is also adhered to. And everything undergoes intensive testing.

“Demand for numerical simulations is constantly increasing.”

When it comes to the design, development and production of antivibration components, no one comes close to achieving the same results: Eray Ulugül heads Research and Development at Laspar Angst + Pfister in Bursa.

Mr. Ulugül, you are a professional in the field of numerical simulation. What fascinates you so much about this subject and how do the customers benefit?

Eray Ulugül: It is mainly my practical experience with the finite element method that is of benefit for our customers. Technical equipment alone is not enough, specific expertise is also needed. We have both. Using numerical simulation with internally developed guidelines and know-how, we can find the right elastomeric characteristic for optimal performance, and this enables us to achieve required hardness and develop

the best design and geometry for a component. Simulating the real-world conditions, to which a sealing or antivibration component is exposed, definitely saves time and development costs. That is why, the demand for numerical simulations is increasing continuously and we are doing all we can to meet this demand.

But that is not the only way to keep development times short.

Eray Ulugül: Our other major advantage at Laspar Angst + Pfister is having everything under one roof – from development, prototyping and testing to metal preparation, compounding and production. The tool for the production of prototypes is manufactured in six to nine weeks, the tool for series production in ten to thirteen weeks. These short periods are due to the fact that our engineering unit makes full use of its proximity to the other areas of competence like mold flow simulation to design vulcanization tools right the first time. We work hand in hand, and the effect is immediately evident to the customer.

And your test systems?

Eray Ulugül: We are well equipped, to examine the rigidity of the components, to test their static and dynamic properties, their vibration absorption and their durability performance and to provide proof of their service life. The results input directly – and quickly – into our further engineering work.

Our in-house rubber batch testing provides leading-edge technology to develop customized rubber recipes with optimal vulcanization process. This enables us to find the right rubber compound for unique applications i.e. high temperature, dynamic to static ratio and rebound value.

Ensuring smooth operation on the tracks and in the carriages Since 1953, Angst + Pfister has supplied the railway industry's leading manufacturers and operators with uncompromisingly high quality products and comprehensive engineering solutions.



Floors and interiors

1

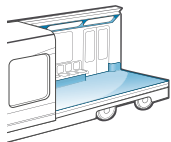

Plastic Finished Products

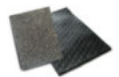

Sound Absorption Mats

Floating floors

2

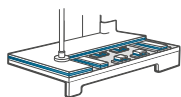

Antivibration Supports



APSOPUR®/
ECOVIB®
Damping Mats

Bathrooms and fixtures

3



APSOfluid®
Water Hose Lines



Couplings

Windows and doors

4

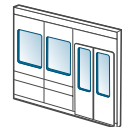

Plastic Finished Products

Railway manufacturers, maintenance organizations and track installers all benefit from our long-standing industry experience and our engineering expertise. Industry leaders rely on Angst + Pfister for standard as well as custom-designed components that meet the highest technical specifications and railway norms. Let Angst + Pfister bundle all the components you need and ship them just-in-time to your international manufacturing facilities.



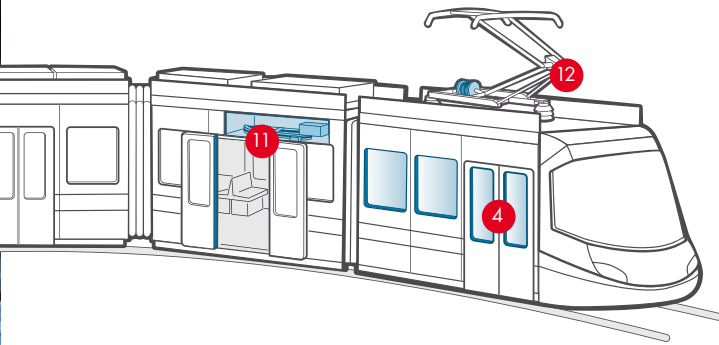

Angst + Pfister's engineering team patents every year new products specifically designed for railway industry in the Antivibration, Sealing and Hosing product areas. Our solutions for railway are all compliant to the most advanced and updated standards, such as DIN EN 45 545 or other nation-specific Smoke and Fire Standards. Our representatives take part in various Standards Committees to ensure our readiness for any upcoming technical requirement.

Our customers benefit from these competitive advantages through a solid partnership with Angst + Pfister which proves time and again that co-design projects are the best solutions to reduce Time-To-Market.

SNCF laboratories, TU Munich, LAPI and LNE: We test and certify our innovations at laboratories which are recognized globally for their expertise. Furthermore, we are proud of our Quality Management process, making Angst + Pfister a market leader in product conformity within the railway industry.

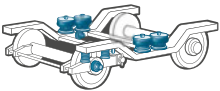





Bogies 5

 Primary Buffers
 HYDROFLEX® Hose Lines
 Punched Flat Gaskets
 Layer Springs

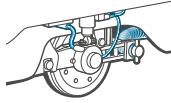

Power converters/ Transformers 6

 ASSIWELL® Hose Lines
 Couplings
 Elastomeric Profiles

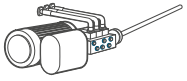

Brake system 7

 Translational & Rotational Seals
 O-Rings/ Round Cords
 Punched Flat Gaskets





Brake compressor 8

 Cone Mounts
 Round Buffers

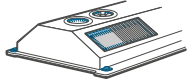

Train junctions 9

 Elastomeric Profiles
 Plastic Finished Products

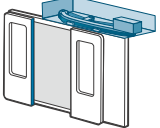

HVAC 10

 O-Rings/ Round Cords
 Cone Mounts and Shear Mounts
 Elastomeric Profiles

Doors opening systems 11

 Belt Drives
 Elastomeric Profiles

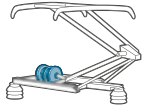
Pantographs 12

 Air Bellows

This rubber compound is naturally fireproof In April 2016, national regulations for fire safety on railway vehicles were entirely superseded by the European standard EN 45 545. Angst+Pfister forged a path for customers to follow in meeting the requirements of the standard: Instead of coating components, a new rubber compound was developed for vibration isolation. Siemens uses these elements to suspend bogies.





© Fotos: www.siemens.com/presse



Advanced technology on the trams: Angst + Pfister's significant input is in the form of vibration technology.

This is a very familiar scenario for Angst + Pfister and even more so for its customers. It's a win-win situation for everyone. The process takes place within the Angst + Pfister Group: In Zurich, Angst + Pfister's group engineering focus their entire efforts on the technological project; the development engineers of Laspar Angst + Pfister in Bursa, Turkey, then input their expertise, which shortens the development time, by applying their numerical simulation capability and because prototype production as well as series production are carried out under the same roof. At the same time, Angst + Pfister's consulting and sales teams, such as Andreas Gogl and his team in Austria, coordinate matters and are in constant contact with Zurich, Bursa and the customer. This is the group who produce antivibration solutions and pride themselves on exceeding expectations.

Angst + Pfister provided the specialist knowledge for the metal-jacketed bone bush for the Avenio low-floor tram, which the city of Munich reordered from Siemens.

Fire safety standard EN 45 545 and further requirements

For Siemens Mobility, who design and manufacture high speed trains, underground trains and trams, it was necessary to combine what at first glance appeared to be two contradictory requirements: Firstly, the new vibration insulation had to meet the requirements of fire safety standard EN 45 545 for the suspension of bogies. Secondly, despite integral fire retardants, the new components had to display approximately the same mechanical properties and the same static and dynamic stiffness as the old components.

Compounding specialists, too

Laspar Angst + Pfister in Bursa also specialize in compounding; the development engineers there have over several iterations of their simulation and testing methods developed a new rubber compound: The compound meets the parameters of the standard and is both a high-performance product and age-resistant. Ultimately, a rail vehicle is designed

for a long life, over ten years is the norm. The fact that the new rubber compound satisfies all requirements has been confirmed by tests in independent external laboratories.

"The fire safety standard EN 45 545 was indeed very challenging for the rail vehicle construction as a whole. But we managed to solve the problem – with the new rubber compound."

Andreas Gogl
Angst + Pfister Austria

Why not coat?

Andreas Gogl of Angst + Pfister Austria comments that a flame-retardant coating of the old components would possibly have produced a similar result. However, Andreas Gogl and his team that work together with the engineers of Siemens Austria and other customers in several Central European countries, noted that in their experience coatings can be damaged

and in terms of ageing resistance cannot keep pace with rubber compounds, which have the required fire resistance already built in. "The fire safety standard EN 45 545 was indeed very challenging for the rail vehicle construction as a whole. But we managed to solve the problem – with the new rubber compound."

Angst + Pfister has used the new compound to design various metal-rubber components for Siemens: for example, a primary layer spring for the Rhine-Ruhr Express running between Cologne and Dortmund, and a metal-coated bone bush for the Avenio type low-floor tram, which the city of Munich has ordered from Siemens again.

"When customers can rely on a single source for everything, they can significantly shorten the time-to-market process, while at the same time being guaranteed an individual solution that is right."

Andreas Gogl
Angst + Pfister Austria

A single source saves time and money

Andreas Gogl stressed the close partnership with Siemens and the matrix of skills available at Angst + Pfister: "Not only can we design the geometry of a vibration isolation system, we can also determine which rubber compound is the right one. And for our Laspar Angst + Pfister colleagues in Bursa, their development, compounding, prototyping and mass production units are just a few metres apart. This proximity and our internal cooperation allow problems to be solved in a relatively narrow time frame and in a cost-to-benefit ratio beneficial to our customer." When customers can rely on a single source for everything, they can significantly shorten the time-to-market process, while at the same time being guaranteed an individual solution that is right, and complies with the fire safety standard EN 45 545.



© Photos: www.siemens.com/press

A comfortable commute over longer distances: The Rhine-Ruhr Express between Cologne and Dortmund at 160 km/h will travel faster than the regional trains.



Fire safety in accordance with EN 45 545 is part of the package: Angst + Pfister designed a primary layer spring for the double-decker trains of the Rhine-Ruhr Express.

For comfortable travel and material wear prevention Travel trends have changed – the requirements facing the rail industry as well. Angst + Pfister addresses this issue with integrated solutions isolating vibration and noise.



The experience of nostalgia: The Furka steam train rolls through Swiss mountain landscape. – The experience of technology: Progress never stops.

The idea of a journey on an old steam train through picturesque landscape awakens in us wonderfully nostalgic emotions. Whereas in times long since past, this new method of transport was revolutionary and pioneering – its importance to both passengers and freight made it easy to suppress the reality of how uncomfortable, noisy and bumpy these journeys must have been.

Technology has been evolving continuously, mainly to meet the need for greater safety and safeguard the health of people, but also in view of a more efficient cost-benefit ratio. Apart from minimising wear and tear as far as possible, the aim is simply to make travel more pleasant and comfortable. Essentially, it is the role of Research and Development to reduce noise emissions, isolate vibration and, of course, ensure fire safety. A major part of their work is outfitting train cars with special floor systems.

The authoritative specialist

Having a background firmly rooted in modern technology, Angst + Pfister is the absolute specialist in this area and a long-standing partner in the development of solutions, the manufacture and selection of specialist materials, as well as finding and analysing products for both regional and national rail companies. High-technology floor systems are a steadily growing market, something that



© Photo: Keystone, Christian Richter

Reduce material wear and vibration, increase travel comfort: Angst + Pfister has solutions.

becomes apparent when considering the big production companies in the rail industry and the business partners of Angst + Pfister, such as Alstom, Hitachi, Siemens and Bombardier – and all will be working at full capacity over the next 3–5 years.

Single source solutions

Angst + Pfister is well established as a trusted partner, not only through many years of experience and specialist know-how in this area, but also due to its comprehensive process optimization work, because effective collaboration is not just about being at the forefront of the latest technology, it is also a question of exactly identifying and anticipating the requirements of your partners and customers. There is a clear trend in the railway industry towards one-stop solutions.

In addition to new advances in the field of R&D, cost optimization and the reduction of installation time and costs, there is also the prime consideration of achieving a more

efficient supply chain management in terms of financial risk and optimization of lead times and on time delivery.

In line with this trend, Angst + Pfister has joined forces with Bellotti and AGT Engineering in offering integrated floor system solutions.

The company Bellotti S.p.A. was founded in 1927 and is anchored in the timber sector, specializing in the production of chipboard panelling. Because panels are only part of the system, AGT Engineering was brought in as the partner with responsibility for designing the entire floor construction.

Various composite materials

Whereas in Europe and Asia, wood and wood composites are the combination of choice, in

the USA laminated wood panels sandwiched between aluminum or composite panels are preferred, due to far stricter fire and smoke safety regulations. Wood is 30%–50% cheaper and its superior thermal and acoustic insulation properties will continue to make it the favoured based material.

The trend in the rail industry is for the customer to prefer a package solution. Angst + Pfister and Bellotti provide just that with their comprehensive floor system that absorbs noise and vibration.



Anti-vibration technology for floor systems: individually designed according to region and standards such as DIN EN 45 545.

Having outstanding expertise in the field of anti-vibration technology, Angst + Pfister can provide for both methods a variety of suitable composite materials. All the solutions offered are fire- and smoke-resistant, and compliant with the relevant EU standard EN DIN 45 545, which has replaced national safety regulations in the EU.

“We work out the best solution with the customer.”



Michael Forrer
Senior Engineer
Angst + Pfister
+41 44 306 6491
Michael.Forrer@angst-pfister.com

Michael Forrer has been a senior engineer in antivibration technology at Angst + Pfister for two years and can already look back on a considerable number of successful projects.

Mr. Forrer, what exactly can you offer customers as single source supplier for floor systems?

Michael Forrer: To begin with, we work with our engineers analyzing in detail the ideas and requirements of the customer.

As an effective and efficient team, we draw on the expertise of our partners and specialists to develop a total package for a customized floor system that covers conception and design through to the choice and production of suitable materials and assembly. We use a combination of wood or aluminum in conjunction with composite materials; demonstrably the best method for providing effective fire protection and effective insulation against vibration and noise. On request, we also provide suitable heating systems for our floor system solutions.

How do these solutions work in practice and what is Angst + Pfister's contribution?

Michael Forrer: The solution is determined by the application purpose and specific requirements. We work closely with our customers to find the right solution for them. We are in a position to be able to manufacture materials that precisely reproduce the characteristics required by the components for the specific application. Usually, a combination of both methods

mentioned is used for the floor system solutions in trains.

An insulating layer made of rubber and metal elements or polyurethane strips, which are available in a variety of sizes, shapes and lengths, is bonded onto the unfinished floor, normally a steel frame consisting of welded tubular steel and metal profiles. The elements isolate the movement vibrations of the moving train and absorb irregularities of wheels and rails. In a partnership project with the former Ansaldo-Breda and today's Hitachi Rail Italy, we used vulcanized chloroprene. The Angst + Pfister product APSOPUR® was used in partnership with Siemens for a flooring system for 65 Milan Metro wagons.

The bonding work is performed in Angst + Pfister's own production facility in Zoetermeer in the Netherlands as Angst + Pfister has the relevant Fraunhofer certificate, certification level A 2 in accordance with DIN 6701-2*.

Chipboard panels with a built-in flexible, sound-absorbing layer are then screwed onto the isolation elements. A product particularly suited to sound absorption is Angst + Pfister's ECOVIB®, a high-quality polyurethane-bonded fine-grained cork combined with recycled rubber. The exceptionally well-insulated floor panels are installed above a durable rubber mat.

Why are ECOVIB® and APSOPUR® particularly suitable for floor systems in trains?

Michael Forrer: ECOVIB® can be used for most floor coverings, from aluminum to steel to parquet or linoleum, and is easily bonded onto all kinds of materials.

Among its outstanding features is its extremely high durability due to external wear resistance and form stability. These excellent properties ensure sustained high performance, thereby saving the customer time and money. ECOVIB® is also 100% recyclable.

APSOPUR® is a special PUR elastomer with a range of use in both cellular and compact form in the railway sector and also in engineering and mechanical engineering. In most cases, APSOPUR® acts as a compression spring. The properties of the spring can be customized by the targeted selection of the type of APSOPUR®, based on footprint and height of the respective design, construction and operational demands. The standard type series has 12 different APSOPUR® densities.

Integral to the fine-celled structure is the deformation volume, necessary for both static and dynamic conditions. This allows elastic support with total-surface load transfer.

Are there any reference projects for successfully implemented floor system solutions?

Michael Forrer: Yes, there are several. For example, working with our partners, we have outfitted 240 wagons for the Milan Metro with a floor mount in the form of a rubber and metal construction. This led to a follow-up order for outfitting another approx. 380 wagons.

For the ÖBB Railjet in Vienna, we have designed floor mounts using APSOPUR® for 65 Siemens wagons.

And currently we are outfitting 29 new Stadler EC250 Bussnang trains for the SBB. An HD rubber and metal solution was chosen for the best-selling Swiss Federal Railways train named “Giruno”, based on our finite element analysis and our extensive compounding expertise.

* See also page 16

Carriage construction: Elastic mountings absorb vibrations and noise

The field of railway carriage construction is discovering the benefits of rigid but elastic and malleable polyurethane: As a floor mounting, the elastomer isolates vibrations and absorbs noise. Siemens is currently at work in Vienna fitting 190 carriages with elastomer strips. Angst + Pfister has built up specific know-how in affixing these safety-relevant parts, and also places this expertise at the disposal of other customers.



The Angst + Pfister production facility in Zoetermeer, Netherlands. One of the European Adhesive Specialists at work.

Anyone who makes his way through a modern train is most likely moving along a double floor. Elastic mountings between the underfloor, on the one hand, and covered plywood floor, on the other, make it possible to forget any unevenness in the wheels and in the tracks. The

mountings not only dampen vibrations, but also reduce noise and sound.

The elastomers in Angst + Pfister's product range are increasingly being used as the material for these flooring structures. They significantly increase passenger comfort, and



An aluminum plate is bonded to the polyurethane blocks. The adhesive bond is just as safety-relevant as the elastomer itself.

above all also extend the useful life of the carriages and their components, thereby facilitating an overall reduction in lifecycle costs.

Siemens is using a high-performance elastomer for the large-scale order which it has received from Russia: This material is required to withstand the harsh climate and large temperature variations that prevail there. In addition, the polyurethane must meet the DIN 5510-2 fire protection standard.

Safety-relevant adhesive bond

An aluminum plate is mounted on the polyurethane blocks. What makes this adhesive bond between the polyurethane and the metal so special is that it is just as safety-relevant as the elastomer itself. It is for this reason that Chief Technology Officer Erich Schmid, who is personally taking care of Siemens out of our headquarters in Zurich, has trained as a European Adhesive Specialist (EAS).

The adhesive work is carried out in the Netherlands, at Angst+Pfister's production facility in Zoetermeer, where an additional four colleagues have completed EAS training.

Absolute precision and reliability

"For the flame-retardant two-component epoxy adhesive to be applied, both the elastomer blocks and the aluminum plates must be completely clean," explains Erich Schmid. The staff must wear silicone free gloves during production. The air in the production

hall must be completely still, because any draft or wind could blow up dust. The temperature has to be kept constant. Throughout the entire production process, members of our staff are accompanied at all times by at least one of the European Adhesive Specialists. They record the stages of the work in painstaking detail in a logbook so that every single step can be retraced. The fact that the Angst+Pfister operation in Zoetermeer meets high standards of precision and reliability is highlighted by its certificate from the Fraunhofer Institute for Manufacturing Technology and Advanced Materials: Upon completion of the corresponding training of specialist staff, it awards Angst+Pfister a certificate of suitability for adhesive work in connection with rolling stock and rolling stock parts in accordance with DIN 6701-2.

Know-how that benefits the customer

"This process has enabled us to acquire new know-how and additional skills," explains Erich Schmid. "This in turn also enables other

customers to benefit." And here, he is thinking not only in terms of professional diligence – the focus in the development of the adhesive process is also on efficiency. "If a customer involves us at an early stage of a project, this has a positive impact on produc-

tion," says Erich Schmid. "We feel responsible – not only for the final result, but also for the manufacturing processes. In engineering, we often succeed in taking a customer's wishes and translating them into solutions that simply no one had previously thought of."

A brief question to conclude: How are the polyurethane blocks installed together with the aluminum plates? Siemens attaches the floor mounts, which vary in length and height, to the underfloor at clearly defined intervals and at right angles to the longitudinal axis of the carriage. The aluminum plate is screwed to the plywood floor, enabling the elastomers to exert their full effect in absorbing vibrations and noise.

The elastomer blocks and the aluminum plates must be completely clean before bonding.



Certificate Fraunhofer class A 2 as specified in DIN 6701-2.



Reducing rail networks' total costs of ownership Track engineers are fitting elastic pads to the underside of concrete sleepers in a far-sighted drive to protect the track superstructure. The sleeper pads dramatically reduce wear and maintenance costs. The tracks last longer, have far less down-time, and operating expenditure over their lifetime is significantly reduced up to a factor of three. The new European standard EN 16730, introduced mid-February 2016, redefines the test procedure for sleeper pads. Angst+Pfister's ECOVIB® USP sleeper pads are tested to this new standard, are approved, and widely in use.

When a train runs over a track or a switch, the ballast underneath is dynamically stressed and shifted.

The individual ballast stones scrape against one another and quickly wear away. Additional ballast is packed in, in an effort to ensure that over the course of time the track does not become displaced. Angst + Pfister's sleeper pads prevent this: They increase the contact surface between sleeper and ballast and stabilize it. The ballast is less compacted, exposed to less friction and better maintains its integrity thus protecting the entire track bed and the track itself. This dramatically increases the track lifespan as well as maintenance and repair intervals, reducing maintenance costs. The sleeper pads have also been proven to reduce noise and improve comfort.

Amortized in two to three years

Angst + Pfister's ECOVIB® Under Sleeper Pads (USP) – consist of a layer of high-quality EVA combined with a connection layer of patented geotextile fabric. They have a lifespan of at least 35 years and are 100 percent recyclable. They increase the supporting surface of the ballast from 5% to 35% and reduce the surface pressure by 25%. Track-laying costs are reduced by a factor of 4. Maintenance and repair costs are reduced by a factor of 2 to 3, and the USP padding cost can be fully amortized in only two years.

All tests passed – go ahead approved

The ECOVIB® USP sleeper pads currently are in use mainly on railway lines in Germany, France, Austria, Hungary, Sweden, the Netherlands, Spain and in Switzerland. They have been fully certified by Deutsche Bahn and the French state railway company SNCF. Other countries have adopted the DB BN 918145-1 certification of the Deutsche Bahn and the CT IGEV 016 certification of the French state railway company. The European standard EN 16730, which came into force on 16 February 2016, regulates the test procedures, test system and their acceptance criteria according to track classification. Individual European countries define their



The sleeper pads pre-cut to suit the horizontal section of the sleeper.



ECOVIB® USP sleeper pads: the special friction-fit method.

own specific requirements based on this. In other words, each country will test the sleeper pads and issue approval for their respective application. There can be no question about Angst + Pfister being heavily involved. Since Angst + Pfister initiated speedy homologation in several countries, the first altogether positive results are now available: France, Italy, Belgium, Austria and Germany and soon several other European countries will all using sleepers equipped with the ECOVIB® USP.

ECOVIB® USP covers the entire spectrum

The new European standard distinguishes between four classes of rail track: two classes for local trains, each with different maximum axle loads and maximum speeds, one class for general train systems and large curve radiuses, and a class for heavy freight trains with a maximum axle load of 300 kN and speed of 200 km/h. There are three types of Angst + Pfister ECOVIB® USP sleeper pads available to fully cover each of these rail classes. Their specific mechanical and elastic properties mean they can be used for all four rail track classes: ECOVIB® USP APYP 5575-7 is hard, 2128-10 medium and 1322-10 soft, that is, highly elastic. The three types with a dynamic bedding module (C_{dyn}) between 0.13 and 0.95 N/mm³ cover the complete range of applications.

- ECOVIB® USP APYP 5575-7
Type “hard”
für C_{dyn} 0,55–0,95 N/mm³
- ECOVIB® USP APYP 2128-10
Type “medium”
für C_{dyn} 0,21–0,29 N/mm³
- ECOVIB® USP APYP 1322-10
Type “soft”
für C_{dyn} 0,13–0,22 N/mm³

Angst + Pfister's expert USP engineers can provide support in testing, defining country specific requirements and new innovative formulations to reach practically any USP specification. The sleeper pads are then manufactured to suit the specific design of each sleeper type.

Patented bonding technology

Fibres make all the difference: Angst + Pfister's ECOVIB® USP sleeper pads have geotextile webbing integrated on one side. Its random fibres lock as the pad is placed into the still wet concrete. The hydration suction of the wet concrete pulls the fibres into the concrete. As the concrete dries and sets, a powerful bond between the concrete sleeper and sleeper pad is created. The pad has now formed a mechanically tight attachment to the concrete body. The high-strength bond carries loads of 1.0 N/mm² and more. This innovative technology is patented throughout Europe; as such it is unique and cannot be copied.



approved according
EU Standard EN 16730



Leading train makers design their railcars with ASSIWELL® all-metal hose systems – for a very good reason! The advanced technology of Angst+Pfister easily meets the most stringent requirements. No matter whether during a Norwegian winter or an Italian summer, the reliable, failure free operation of locomotives is the number one consideration.

ASSIWELL® all-metal hoses are chiefly deployed in the cooling of the current inverters and transformers. In both cases, heat is produced, which has to be dissipated. Angst+Pfister is fitting the trains with high-quality cooling systems that are individually designed to ensure the circulation between cooler and converter and transformer respectively. These systems are characterized by their many junctions and narrow bending radii. ASSIWELL® metal hose systems are available in very small to very large nominal diameters and offer extreme flexibility and tight bending radii no matter the size.

An exceptionally wide temperature spectrum, very long life span

The trains, or more precisely their components, have to withstand a temperature range from -40 to +80 °C over an operating period of 40 years. The temperature range for using ASSIWELL® all-metal hose systems is far greater than the demanded requirements and consequently the temperature variation during normal operation on the tracks is not a major strain. Nor the requirement for 40 years of reliable service. Ozone and other weather conditions have hardly any effect on the all-metal hose systems.

Angst+Pfister's metal hoses are not only temperature- and ageing-resistant, but also flexible and impermeable.

Fully impermeable

Not only temperature and weather conditions affect the materials, but there is also the significant stress from the ever-present vibration and movement on the tracks. Angst+Pfister has long-term experience in finding the best combination of metal pipes, metal hoses and fittings. The resulting hose system is not only durable and flexible, but also absolutely impermeable.

Fire safety in accordance with DIN EN 45 545

Rolling stock is subject to very strict fire safety laws. If a train is on a track with many tunnels or long tunnels, the requirements are even stricter. The ASSIWELL® all-metal hoses made of stainless steel are non-combustible and therefore ideal in meeting the requirements for the inflammability of materials and components.



A strategic partner rather than a single supplier

Long-term projects with high specificity and high investment require long-term partners. These project characteristics apply to the construction of rolling stock: It takes years to move from ordering to delivery of the completed trains and the construction of each model is characterised by specific requirements and conditions. Angst + Pfister offers its customers single source engineering, production and logistics. The service begins with the custom design of the metal hose appropriate to the problem to be solved. Angst + Pfister fluid technology experts, application-oriented engineers with many years of comprehensive experience, advise and support customers throughout the entire development phase, often directly on-site. As a result of 3D prototyping, the ASSIWELL® experts can build the hose directly into the virtual model of the customer. Changes and adjustments can be responded to quickly. The metal hose systems are manufactured in Angst + Pfister's Embrach workshop. Attention to the individual logistics requirements of the customer is part of the service. When all this is provided reliably and competently by one source, that is what makes a true strategic partner!

Major advantages in comparison to conventional solutions

Cooling systems are often designed with elastomer hoses. The material is, however, vastly inferior to metal when it comes to ageing resistance. Over time it becomes porous and fine leaks result. If a leak is not discovered and cooling is no longer adequate, the consequences can be devastating. Fixed metal pipes may well be durable and impermeable, but have virtually no tolerance. In addition, individual installation is complex and expensive. Fixed metal pipes also put more weight on the track than the ASSIWELL® solution. In rail transport, greater weight is associated with higher power consumption and therefore higher operational costs.

Angst+Pfister is a leading manufacturer of metal hose systems

Perfectly manufactured and perfectly welded, both hose and connection fittings require maximum production precision, because only perfect fitting work pieces can be perfectly welded, which avoids inherent stress in the material. Twenty highly qualified personnel at the Angst + Pfister workshop in Embrach perfectly weld the all-metal hoses to their connecting parts. ASSIWELL® all-metal hose systems are always of an impressively high quality no matter whether they are intended for quick, project-oriented production of prototypes or high-volume automated production. And the quality is guaranteed: Angst + Pfister is certified at the highest level in accordance with DIN EN 15085-2 CL1 for the mechanized welding of railway vehicle parts.

Products and services with added value

ASSIWELL® all-metal hose systems exemplify reliable sealing and as such, operating reliability and durability. As there are fewer connection components compared with other solutions, installation time and costs are reduced. But it is not simply the purchase and installation costs of Angst + Pfister's solutions that win you over, it is also the fact that the life cycle costs are also reduced due to firstly the decreased weight and the consequent reduction in power consumption and then secondly the very high ageing resistance of the product. Angst + Pfister has equally high quality targets. Customers appreciate the many years of experience and reliability, on-site advice and the support during the construction process (including 3D modelling and prototyping). During the production phase, speed and adaptability are what counts, both of which Angst + Pfister offers its customers. Angst + Pfister and the leading manufacturer of rail vehicles – now that is expertise that complements itself, that reaps rewards and serves us well!

The highly qualified personnel of Angst + Pfister execute the welding of the all-metal hose with precision and perfection.



ASSIWELL® hoses: braided with metal.

New applications for double-walled hoses Double-walled hoses can transport two different media. In other applications, the double wall increases safety. But double-walled hoses may also be costly. However, it doesn't have to be like this. Angst + Pfister has optimized the manufacturing process of the double-walled all-metal corrugated hose ASSIWELL®. This has reduced costs and opened up new fields of application.



Double-walled hoses: now even more compact, but qualitatively the same.

It makes sense to use only one hose to transport two different media. Space and weight are saved. The double-walled hose has proven successful in other areas too: For example, where a combustion engine is operating, it will be hot. Therefore combustible media, such as fuel or oil, are better transported in a double-walled hose. It minimizes the risk of fire, because the inner hose filled with fuel is protected. All these advantages are already well-known to rail vehicle designers: Angst + Pfister's double-walled ASSIWELL® hoses have been in use for more than 20 years – and known to be reliable and extremely durable. Used in locomotives and other rail vehicles, they have covered distances equivalent to millions of times the earth's circumference.

With and without abrasion protection, separation gap variable

The engineers at Angst + Pfister install entire hose systems tailored to the precise requirements and needs of customers, and also perform all compulsory system tests. If required by the application, the engineers provide abrasion protection in the form of a fiberglass braid or a layer of heat-resistant PPS between the two ASSIWELL® hoses, thus preventing them from rubbing against or knocking each other. This is recommended particularly for high vibrations. Another option is

the fiberglass braided inner and outer hose. The end-use application of the double-walled hose also determines the distance between the outer and inner hose. If the neutral space is intended purely for monitoring in order to immediately discover a potential leak in the inner hose, then this space only needs to be small.

More compact structure, same high quality

The double-walled hose can perform any number of functions, and specifically for rail vehicles, these are still increasing: Angst + Pfister has made its double-walled ASSIWELL® stainless steel hoses more compact and at the same time optimized production. In terms of quality, the hose has lost nothing: It complies with the EN 15085-2, which regulates the welding of rail vehicle parts, and it meets the ASME standards of the American Society of Mechanical Engineers.

At the Global Logistics Center near Angst + Pfister's Zurich headquarters, certified welders work partly manually and partly at mechanized welding stations. Their standard procedure involves checking each finished welded hose, including the valves, for impermeability in water at 5 bar. A helium leak test and pressure tests are also part of the service. This ensures that a high-quality product that fulfils all requirements in terms of quality, safety standards and cost streamlining is delivered to the customer.

A development partner for all fluid components

During the development of its new generator, JENOPTIK involved Angst + Pfister as its design partner and fluid technology solution provider.

One development day at the customer's site with two Angst + Pfister engineers, two designers and JENOPTIK's project manager proved to be the start of a successful collaboration. As a development partner with many years of experience in the rail industry, Angst + Pfister provided expert advice on the selection of hose and hose line routing and the best configuration of the hose components. Within a very short period of time while working in close collaboration with the customer, Angst + Pfister's engineers came up with a comprehensive solution consisting of ASSIWELL® all-metal hoses, EPDM hoses, silicone turbocharger hoses and hydraulic hose systems.

The customer requirements were: a development partner and supplier who takes care of all the fluid components, a short development phase, highest quality in the manufacture of the welded components with an extremely short production time and tight deadlines. Angst + Pfister met this challenge with considerable enthusiasm: competence, reliability and fast response times make Angst + Pfister an ideal development, production and logistics partner.

The biggest challenge: time! Within only four weeks, Angst + Pfister's senior engineer Norman Wijeyratne created one 3D drawing set and all the working drawings including

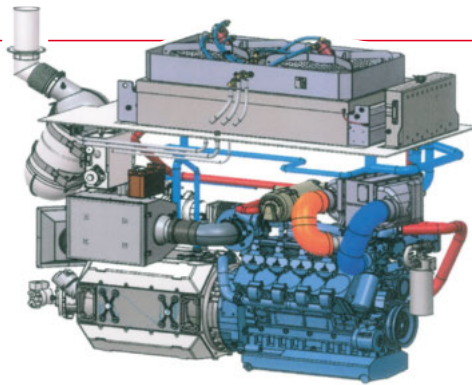

From the schematic diagram to the prototypes and finished generator: Angst + Pfister is dedicated to the design and production of all technical fluid components.

all the detailed dimension information. All the ASSIWELL® all-metal hoses, silicone form hoses and hydraulic hoses systems were made during extra shifts over Christmas and the New Year by our highly dedicated production staff.

"In very close cooperation with the JENOPTIK designers and under considerable time pressure, we developed all the fluid-technical products and delivered excellent quality within the extremely short delivery

time. Consequently we proved ourselves as an engineering partner, as a producer of very high-quality products and as a particularly flexible manufacturing partner," says Manfred Artinger, leader of Fluid Handling Technology at Angst + Pfister Germany.

The sealing frame for the locomotives of Switzerland In Switzerland, everyone knows the Re 460 locomotives of the Swiss Federal Railways (SBB) that have been in service for 20 years. Now they are being modernized so that they can keep going for another 20 years. Even the roof filter is being replaced. Angst+Pfister has developed a sealing frame, which speeds up assembly and complies with the European fire safety standard EN 45 545 for rail vehicles.

The country may be small, but the rail network is widely branched. Every day, the 119 Re 460 class locomotives run a distance calculated by SBB to be 2.5 times the earth's circumference. The bright red locomotive, popularly known in Switzerland as Lok 2000, has become an established part of the Swiss image – and it will continue to be so. All the locomotives will be rolled into the SBB industrial plant at Yverdon-les-Bains to be completely overhauled and modernized. As of spring 2017, the first modernized locomotive will be back on the tracks: running more energy efficiently, sparkling clean and almost like new.

Complex assembly? A thing of the past!

The modernization program will also replace the side filter grilles on the roof structure. Until recently, the grille frames had been installed by pressing them into a clamping profile, which consisted partly of foam rubber and partly of PVC with steel reinforcement. Attaching the clamping profile was a complex process: A technician in SBB's plant in Yverdon-les-Bains had to cut lengths which were then accurately glued and fitted into the corners of the rectangular opening in the roof construction, so that the bonding between the roof and the filter formed a secure seal. The technician also had to wait for the adhesive to bond correctly before screwing the frame with the filter grille to the roof. But that is all in the past. Sébastien Gaillard,

an Angst+Pfister application engineer specialising in sealing technology, has developed a sealing frame, which can be delivered to Yverdon-les-Bains ready to assemble. The technician carrying out the assembly no longer has to measure, cut or glue and there's no more waiting. They only need to insert the sealing frame, and the metal frame including the filter grille can be screwed on straight away. Finished!

Clever design leads to well-thought-out design

The sealing frame has to be flexible so it can be inserted. As a result Sébastien Gaillard had to do without steel reinforcement. He compensated for the loss of rigidity with a thicker profile. And instead of a single sealing lip, he drew two which allows the new profile to perfectly fit the metal frame.

Foam rubber was now also out of the question. The new seal is made from one EPDM, and this is certified according to DIN EN 45 545.

The now European-wide standard governs fire safety in rail vehicles. Because foam rubber was no longer being used, another design change was required as the upper section of the profile, unlike the lower section, has to be highly deformable allowing it to be inserted into the space provided.

In this way, the sealing frame, although made throughout of only one elastomer, fulfils an entirely different function in the lower section than the upper section. Sébastien Gaillard optimized the overall geometry through several iterations and then submitted several variations to the client, the Swiss Federal Railways. In order to validate the solution, he provided cost-efficient, waterjet-cut samples which finally confirmed the decision.

Production advantages and economic benefits

No more steel reinforcement, no more foam rubber – which in effect also opens up new possibilities in production: The sealing frame

can be produced by means of hot vulcanization and is ready to fit. The corners of the sealing frame are tailored using a special tool. It guarantees the necessary cavity in the upper, flexible part of the profile, allowing it to fill the free space in the corners.

Angst+Pfister has designed a solution for

the Re 460 locomotive that is technically impressive, complies with the new fire safety standard DIN EN 45 545 and is also economically attractive to the SBB.

“The installation of a sealing frame used to take us around 20 minutes”, says Re 460 project leader Florian Lantz of the SBB production site in Yverdon-les-Bains. “Now we are able to achieve this within 5 minutes. With 16 frames per roof this means substantial time saving.”



SBB and Angst+Pfister also developed an appropriate solution for rearview mirrors: the material for the silicone sealing is compliant with the European fire safety standard EN 45 545.



For maintenance the roof of the locomotive is removed. The original sealing frame for the filter grilles is clearly visible. It was cut to the correct length and glued to the corners.

Angst+Pfister has also defined the production process for the isolation. The savings easily offset the design costs.



Installing power converters in high-speed trains

Coming soon, the Stadler high-speed EC250 rushes through the Gotthard base tunnel and Angst + Pfister is onboard: The power converter of ABB is installed on the underside of the railcar with completely new vibration-insulating components. The mounts are designed to reduce weight and minimize size while isolating the power converter from the train and reducing downtime. Development time was also minimal.

The success of a whole system often depends on seemingly minor details: In a modern rail transport vehicle, there mustn't be any noises from fans or other components transmitted into the passenger area. Consequently, these auxiliary power units have to be mechanically decoupled by using high-performance isolation elements. Which is why the engineers of ABB Switzerland turned to Angst+Pfister. The hanger elements, needed for the power converter, had to provide optimal vibration and acoustic isolation, while weighing as little as possible, and taking up as little space as possible. The specifications were crystal clear, as was the window for development of just a few weeks.

Please meet all requirements asap

As a senior engineer specialized in anti-vibration technology at Angst + Pfister, Raphael Friedli knew very well that time would be short. But he also knew that it could be done. As always: At the beginning, requirements accumulate at an alarming rate: security against tearing off, isolation frequency ratios, dynamic forces with tension loads and thrust, all make the initial specifications appear impossible to reconcile.

Previously inconceivable solutions emerge from empirical knowledge and numerical simulation.

From empirical knowledge and state-of-the-art data simulation, a solution emerges which previously would hardly have been conceivable. Angst + Pfister's engineers in

Zurich and their R&D engineering colleagues at Laspar Angst + Pfister in Bursa, Turkey, working with numerical simulations including finite element analysis jointly produce the perfect design. This in turn dramatically reduces production costs. It was the

same for ABB as for the automotive industry: Applying the finite element method reduced the co-design process to only a few design



manufactured with the standard casting method. The brackets are produced by the deep-drawing process. This new solution allows production at much lower costs. The change in this production process, enabled by the ability of the Angst + Pfister engineers to think outside the box, resulted in a significant cost out of the design. The component, which also has been optimized structurally, requires less material, weighs less, and takes up less space – all vitally important considerations in the competitive world of rail vehicle construction today. A special coating renders the metal bracket corrosion-resistant, ensuring a long service lifetime.

Engineering and manufacturing working hand in hand

ABB can also leave the production of elastomeric bearings and the metal brackets to Angst + Pfister: Engineering and production are working under one roof at Laspar Angst + Pfister in Bursa. The design engineers are working directly with the production and the local supply chain to minimize costs while ensuring quality. The tooling and prototype production is next to the R&D office to increase the speed of development and production efficiency. All this made it possible to deliver the pilot prototypes exactly according to schedule.

The Stadler Rail EC250, or “Giruno” as the purchaser, the Swiss Federal Railways, call the trains, will soon run at up to 250 km/h between Frankfurt and Milan through the longest railway tunnel in the world. Engineering ingenuity, on a scale both large and small, has made this travel experience possible.

loops, resulting in a highly customized isolation element.

A metal bracket saving space, weight and cost

The power converter, with its twelve cast supports, sits directly on top of twelve of these anti-vibration insulators. These in turn are bolted to the underside of the wagon body by means of metal brackets. The bracket geometry and how it should be manufactured were also determined by numerical simulation. Previously, such parts were

APSOvib[®]-mounts, -isolations and -brackets comply with the fire safety EU Standard 45 545 for rail vehicles.

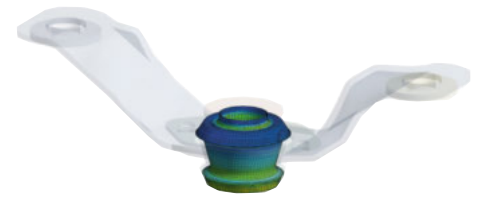

The design of vibration isolators, on which the power converter is mounted, ...

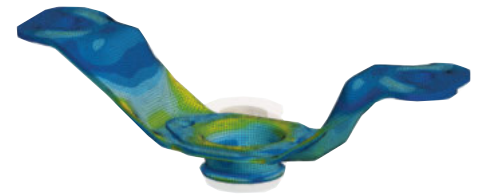

... and the design of the metal bracket with which they are bolted to the undercarriage,

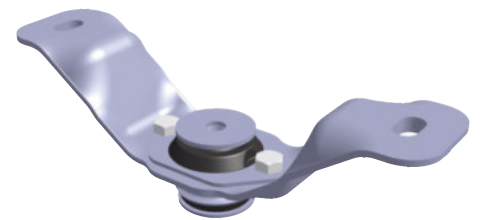

are the result of numerical simulation. The component, which is also structurally optimised, requires less material and space.



There are twelve attachment points between the power converter and undercarriage.

APSOPUR®: including an all-round service also designed to excel APSOPUR®, Angst+Pfister's antivibration insulation conquers the south. Excellent performance is not the only factor winning over Locarno in Italian-speaking Switzerland. APSOPUR® mats of polyurethane foam are easy to install, Angst+Pfister provides a complementary engineering support and all-round logistical service, this is welcomed as a competitive plus by customers.



An apartment building is to be built on top of a railway tunnel. The building will be elastically suspended to prevent transmission of vibration from the trains.

Time appears to have stood still. The train rolls on. Beyond the window, forests, vineyards, chestnut groves and small villages pass by. The Centovalli railway is both a tourist attraction and a practical means of transport. It connects Locarno with Domodossola 52 km away, via the Swiss-Italian border. The route crosses 83 bridges and passes through 34 tunnels at a height climbing from around 200 to more than 800 m and then descending again.

On the Via Felice Bianchetti in Locarno, however, time and technology have by no means stood still. A newly constructed apartment building has been built partly straddling one of the Centovalli railway tunnels. To dampen vibrations from the train run-

ning beneath, the building has been resiliently bedded. Angst+Pfister acted as technical advisor to Alessandro Bonalumi, the engineer commissioned for the project and selected suitable products from its wide APSOPUR® range. Once again, cost-effective standard materials provided the means for a tailor-made solution designed precisely to suit the various static loads and the dynamic loads requiring dampening.

Both Alessandro Bonalumi's engineering firm PIANIFICA Ingegneri SA and developer Giorgio Laudi of the eponymous property company worked together with Angst+Pfister some years ago on a different construction project in Locarno. They knew each other and were well aware of the high quality product and construction standards expected by all parties. Alessandro Bonalumi clarifies: "Passive building insulation is chal-

lenging. Once in place, it cannot be corrected retrospectively. Errors or defects are simply not part of the equation." Hence the importance of the involvement of an experienced building physicist, explains Alessandro Bonalumi. He contacted Armin Ziegler, an engineer specializing in antivibration insulation construction.

Antivibration specialists stayed on track

Their measurement of anticipated loads and vibrations and analysis formed the groundwork for the extreme reliability of the calculation for the antivibration and sound insulation. From the subsequent evaluation of potential solutions, it was APSOPUR® devel-

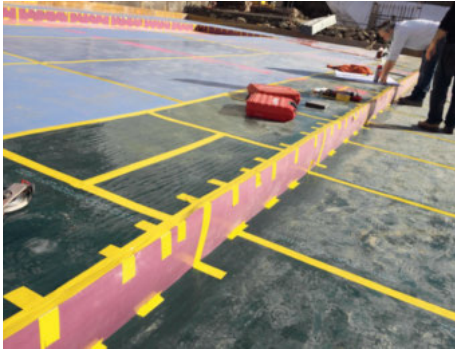

Angst + Pfister is training the construction workers so that they can attach the mats themselves.



The right APSOPUR® antivibration mat for installation is selected according to surface pressure.

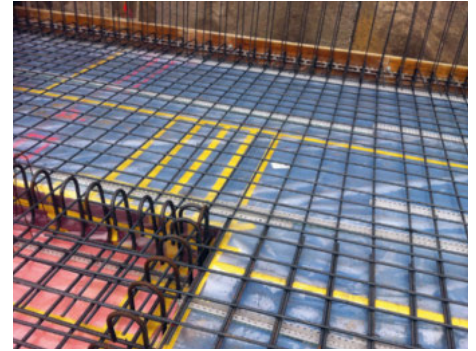

Cover with plastic wrap, then reinforce and concrete. It's as easy as that.



oped by Angst+Pfister that took the lead. APSOPUR® unites the typical Swiss characteristics of precision, reliability and efficiency. The antivibration specialists at Angst + Pfister were able to provide a suitable APSOPUR® product for all the various contact pressures encountered at the location. And of course they kept their promise to instruct the workers on-site on how to lay the insulation layer, so that the contractors could do the work themselves. Laying APSOPUR® insulation mats on concrete foundations is not rocket science – as long as care is taken to work cleanly and precisely. It was also a matter of course for Angst+Pfister to cast an expert eye over the finished floating floor before it was covered by the protective plastic film and the reinforcement for the concrete floor was put in place.

Notwithstanding the extreme dependability of both APSOPUR® and Angst+Pfister, completion of the apartment block shell structure was nonetheless greeted with great excitement: Armin Ziegler took his high-precision equipment to six predefined measuring points on the first floor and the building's foundations. Five devices measured the vibrations during a total of 26 train crossings and one recorded structure-borne noise, which can result from the vibrations.

Great measurement results

concluded the independent antivibration expert: "The flexible bedding of the residential building is an out-and-out success." The vibration and sound results that he obtained

are far below the guideline limits generally applied in Switzerland. Even though the tunnel roof is not even five metres thick, vibrations will only be faintly felt and structure-borne noise will be virtually imperceptible. The figures took into account the effect of the as yet absent furniture and equipment. Once the doors have been installed and the floor underlay, they will reduce even more. "The solution is a winner", says Alessandro Bonalumi. The apartment building on the Via Felice Bianchetti in Locarno meanwhile has been completed and fully occupied.

EN 45 545 Fire Protection Certificates on Angst + Pfister products





© Photo: www.fotolia.com

APSOvib® Antivibration Technology

Part type		Material	Hardness ShA +/-5	EN 45 545
Antivibration elements for bogies (layer springs, primary buffers, round and stop buffers)		NR	50 ShA	R24: HL2
		NR(BR)	70 ShA	R24: HL3
Floor supports		CR	45 ShA	R10: HL2
		CR	49 ShA	R9: HL3, R10: HL3
		CR	70 ShA	R9: HL3, R10: HL3
		EPDM	46 ShA	R10: HL3
Floor supports – Metal Cushion		Metal Cushion		> HL3
Floor supports – PUR metal		APSOPUR® L55 (12.5 mm)		R10: HL3

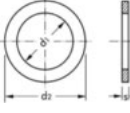
APSOseal® Sealing Technology

Part type		Production technology	Material	Type	Hardness ShA +/-5 (Density g/cm ³)	EN 45 545
Molded parts, molded flat gaskets, o-rings		Compression	EPDM	Compact	70 ShA	R22: HL3, R23: HL3
			VMQ	Compact	40 ShA	R22: HL3, R23: HL3
			VMQ	Compact	70 ShA	R22: HL2, R23: HL3
Flat gaskets		Punching	EPDM	Compact	70 ShA	R22: HL3, R23: HL3
			VMQ	Foam	(0.16 g/cm ³)	R22: HL3, R23: HL3
			VMQ	Foam	(0.208 g/cm ³)	R22: HL2, R23: HL2
			VMQ	Foam	(0.35 g/cm ³)	R22: HL3, R23: HL3
			VMQ	Foam	(0.43 g/cm ³)	R22: HL3, R23: HL3
Elastomeric profiles		Extrusion	EPDM	Compact	50 ShA	R22: HL2, R23: HL2, R24: HL2
			EPDM	Compact	60 ShA	R22: HL3, R23: HL3, R24: HL3
			EPDM	Compact	65 ShA	R22: HL3, R23: HL3
			EPDM	Compact	70 ShA	R22: HL3, R23: HL3
			EPDM	Compact	75 ShA	R22: HL3, R23: HL3
			EPDM	Compact	77 ShA	R22: HL3, R23: HL3
			EPDM	Foam	(0.8 g/cm ³)	R22: HL2, R23: HL2
			EPDM	Foam – mixed closed and open cells	(0.8 g/cm ³)	R22: HL2, R23: HL2
			VMQ	Compact	40 ShA	R22: HL3, R23: HL3
			VMQ	Compact	50 ShA	R22: HL3, R23: HL3
			VMQ	Compact	60 ShA	R22: HL3, R23: HL3
			VMQ	Compact	70 ShA	R22: HL3, R23: HL3
			VMQ	Foam – Closed cells	(0.35 g/cm ³)	R22: HL3, R23: HL3
VMQ	Foam – Closed cells	(0.55 g/cm ³)	R22: HL3, R23: HL3			

APSOfluid® Fluid Handling Technology

Part type	Product	Material	EN 45 545
Industrial hoses	Conveyance hose for water	EPDM	R22: HL3 R23: HL3
	Cable protection hose	EPDM and NBR	R22: HL3 R23: HL3
	Cable protection hose	Silicon	R22: HL3 R23: HL3
	Air brake hose	CR	R22: HL3 R23: HL3
Hydraulic hoses	Hydraulic hose Type 2TE	NBR/EPDM	R22: HL3 R23: HL3
	Hydraulic hose Type 1SC	NBR/EPDM	R22: HL3 R23: HL3
	Hydraulic hose Type 2SC	NBR/EPDM	R22: HL3 R23: HL3
	Hydraulic hose Type 1SN	NBR/EPDM	R22: HL3 R23: HL3
	Hydraulic hose Type 2SN	NBR/EPDM	R22: HL3 R23: HL3
Metal hoses	ASSIWELL® metal hoses	Stainless Steel	> HL3

APSOplast® Engineering Plastics Technology

Material	Type	EN 45 545
UP-HLM FR	Hand layup GRP Laminate	R1, R2, R3: HL2
UP-GRP	Pultrusion profile	R1, R2, R3: HL3 R22, R23, R24: HL3
UP-GM 203	Red/white	R1, R2, R3: HL2 R22, R23, R24: HL3
EP-GC 202	Natural, (Yellow/brown)	R7, R17: HL2 R1, R2, R3, R11, R12, R22, R23, R24: HL3
PE-UHMW FR	Black	R7: HL2 R10, R24, R26: HL3
PA 66 FR	Black	R17, R23: HL1 R24, R26: HL3
PA 6 FR	White	R22, R23, R24, R26: HL3
PA 6 FR	Extrusion profile, coloured	R22, R23, R24, R26: HL3
PC FR transp	Transparent, flame-retardant	R4: HL3

In addition to this range of products, we can supply you with special and/or customized products up on request at any time: consult us!

Angst + Pfister Group: Your leading supply and solutions partner for industrial components.

Our core product divisions



**APSOplast® Engineering
Plastics Technology**



**APSOseal®
Sealing Technology**



**APSOfluid® Fluid
Handling Technology**

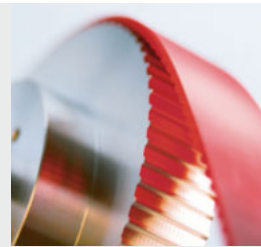

**APSOdrive®
Drive Technology**



**APSOvib®
Antivibration Technology**

The Angst + Pfister Group is a leading international technical manufacturer and service provider for high-end industrial components. As a supply and solutions partner

for engineering plastics, sealing, fluid handling, drive, and antivibration technology as well as sensors, Angst + Pfister combines efficient logistics concepts with comprehensive product application engineering ser-

vices. Besides providing customer-specific parts, the Group offers a product range consisting of approximately 100 000 standard items.

Switzerland

Angst + Pfister AG
Thurgauerstrasse 66, Postfach, CH-8052 Zürich
Phone +41 (0)44 306 61 11
Fax +41 (0)44 302 18 71
www.angst-pfister.com, ch@angst-pfister.com

Angst + Pfister SA
Chemin de la Papeterie 1, CH-1290 Versoix
Phone +41 (0)22 979 28 00
Fax +41 (0)22 979 28 78
www.angst-pfister.com, ch@angst-pfister.com

Germany

Angst + Pfister GmbH
Schulze-Delitzsch-Strasse 38, DE-70565 Stuttgart
Phone +49 (0)711 48 999 2-0
Fax +49 (0)711 48 999 2-2569
www.angst-pfister.com, de@angst-pfister.com

France

Angst + Pfister SA
Immeuble DELTAPARC
93, avenue des Nations, FR-93420 Villepinte
Phone +33 (0)1 48 63 20 80
Fax +33 (0)1 48 63 26 90
www.angst-pfister.com, fr@angst-pfister.com

Austria

Angst + Pfister Ges.m.b.H.
Floridsdorfer Hauptstrasse 1/E, AT-1210 Wien
Phone +43 (0)1 258 46 01-0
Fax +43 (0)1 258 46 01-98
www.angst-pfister.com, at@angst-pfister.com

Italy

Angst + Pfister S.p.A.
Via Montefeltro 4, IT-20156 Milano
Phone +39 (0)2 8295 9700
www.angst-pfister.com, it@angst-pfister.com

Netherlands

Angst + Pfister B.V.
Boerhaavelaan 19, NL-2713 HA Zoetermeer
Phone +31 (0)79 320 3700
Fax +31 (0)79 320 3799
www.angst-pfister.com, nl@angst-pfister.com

Belgium

Angst + Pfister N.V. S.A.
Bedrijvencentrum Waasland Industriepark-West 75
BE-9100 Sint-Niklaas
Phone +32 (0)3 778 0128
Fax +32 (0)3 777 8398
www.angst-pfister.com, be@angst-pfister.com

China

Angst + Pfister Trade (Shanghai) Co. Ltd.
Rm 1402, West Tower,
Zhong Rong Hengrui Building
No. 560 Zhongyang Road, CN-Shanghai 200122
Phone +86 21 5169 5005
Fax +86 21 5835 8618
www.angst-pfister.com, cn@angst-pfister.com

Turkey

Laspar Angst + Pfister
Advanced Industrial Solutions A.Ş.
Akçalar Sanayi Bölgesi Kale Cd., No: 10,
TR-16225 Nilüfer/Bursa
Phone +90 224 280 69 00
Fax +90 224 484 25 96
www.lp-ap.com, info@lp-ap.com

Poland

Angst + Pfister Sp. z o.o.
ul. Szyprów 17, PL-43-382 Bielsko-Biała
Phone +48 33 443 29 70
Fax +48 33 443 29 71
www.angst-pfister.com, pl@angst-pfister.com



APSOparts®

the Online Shop of Angst + Pfister
www.apsoparts.com